

Compressed Air Treatment

The quality of untreated compressed air is no longer sufficient for most applications today and would result in quality reductions in compressed air products. This may mean disturbances of production systems right up to lost output or unusable products, i. e. a clear and critical reduction of product quality. The compressed air application determines the air quality required.

Class	Maximum number of particles/m ³			Pressure dew point (°C)	Remaining oil content (mg/m ³)
	Particle size d (µm)	0.1 < d ≤ 0.5	0.5 < d ≤ 1		
0	specified according to application and better than Class 1				
1	100	1	0	≤ -70	0.01
2	100000	1000	10	≤ -40	0.1
3	–	10000	500	≤ -20	1
4	–	–	1000	≤ +3	5
5	–	–	20000	≤ +7	–

Table 1: Purity classes under DIN-Norm ISO 8573-1

The maximum loads with particles, water and oil are divided into purity classes in the DIN norm ISO 8573-1. This allows manufacturers of compressed air products to define the required quality.

Drying compressed air

The different methods of drying compressed air can be classified as shown in Fig. 1 using the achievable pressure dew point and the energy necessary for this: depending on the system, the energy demand is recorded as compressed air or as electrical energy.

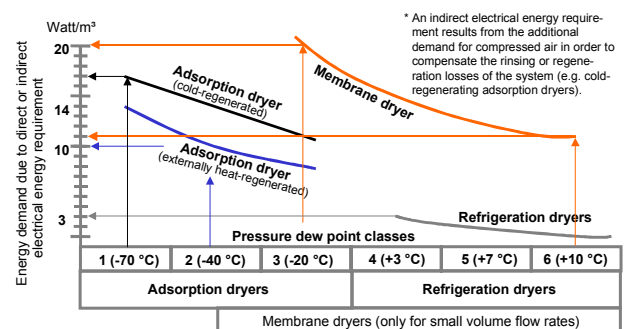

Fig. 1: Methods of drying compressed air

Refrigeration dryers

Refrigeration dryers are state-of-the-art today in compressed air systems and just as important as the compressed air producer itself. Furthermore



Compressed Air

Facts

they represent the most economic process for the majority of applications.

Physical basis:

The ability of compressed air to conduct water decreases with falling temperature. When the temperature drops, the water vapour condenses to water. The refrigeration dryer extracts the water vapour contained in the compressed air. To achieve this, the compressed air is cooled in a heat exchanger system. Water and oil vapour are extracted by condensation, oil by coagulation and coalescence. The condensate is drained off.

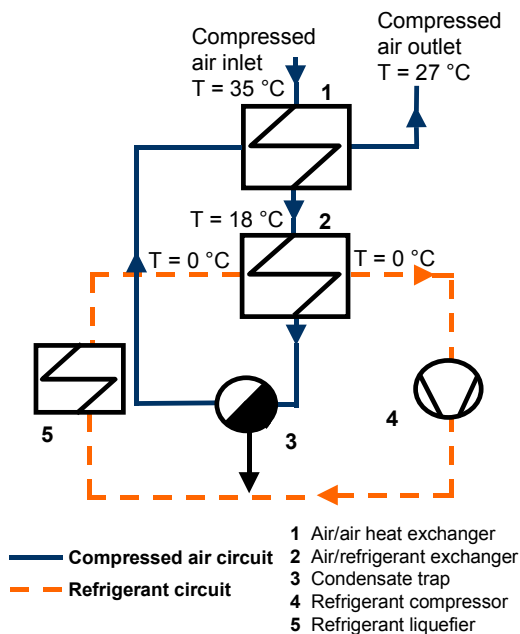

Fig. 2: How the refrigeration dryer functions

Economic refrigeration drying is divided into two phases. In the first phase, the warm incoming compressed air is cooled by the already chilled exiting compressed air in the air to air exchanger. Approx. 70 % of the accumulated water vapour are precipitated here. In the second phase, the compressed air flows through a coolant/air heat exchanger. This is where cooling to the required pressure dew point occurs. The condensate trap is downstream from the heat exchanger. The condensate is separated here from the compressed air.

Integrated heat exchanger systems which integrate air to air exchangers, coolant-air exchangers and condensate traps in one system component are more energy-efficient due to lower differential pressures compared to separate casings.

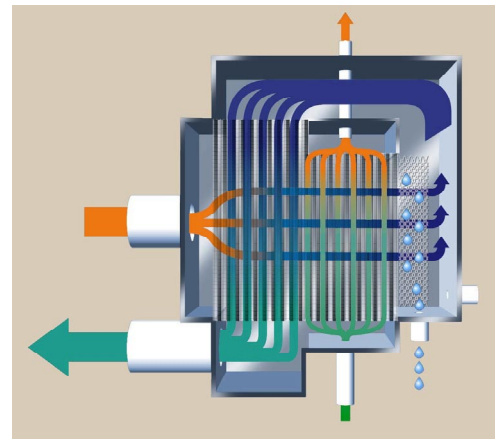

Fig. 3: Heat exchanger with integrated condensate trap (demister)

Adsorption dryers

Adsorption dryers extract the humidity carried in the compressed air using a desiccant. While adsorption takes place in the first container, the desiccant is regenerated at the same time in the second container. Pressure dew points between -20 and -70 °C can be achieved with standard products. There are various processes available for the regeneration. A distinction can be made between cold and warm regenerated adsorption dryers depending on the type of regeneration involved.

Cold regeneration

For the regeneration, some of the already dried compressed air is depressurised to atmospheric pressure.

- + simple technique
- + low investment costs
- consumption of compressed air
- high operating costs.

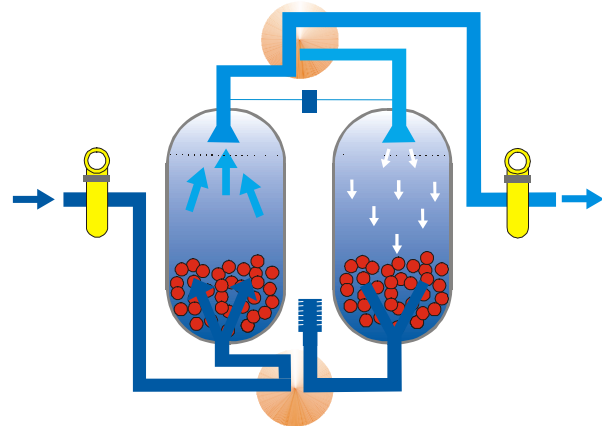

Fig. 4: Cold regeneration

Heated regeneration

Regeneration takes place with heated ambient air or heated air from the system.

Blower regeneration

In the heating phase, a blower forces ambient air through the heating. The heated air transports the humidity from the desiccant bed. Ambient air and compressed air are used for cooling.

- + lower operating costs by heating with steam or electrical energy
- compressed air consumption in the cooling phase.

Heated regeneration without using compressed air

By modifying the set-up and procedure, the desiccant bed can be cooled using ambient air. These adsorption dryers are divided into blowing, suction cooling or vacuum regeneration systems.

- + Lower operating costs by heating with electrical energy or steam
- + no consumption of compressed air in the cooling phase
- higher investment costs
- restricted use if ambient air is very humid.

Compressor heat regeneration

When using oil-free compressors in combination with adsorption dryers, the heat generated during compression is used specifically for the regeneration of the adsorption dryer. Pressure dew points of $-30\text{ }^{\circ}\text{C}$ and better are guaranteed by suitable compressors.

- + Uses the compression heat for regeneration
- + no consumption of compressed air
- only with oil-free compressors.

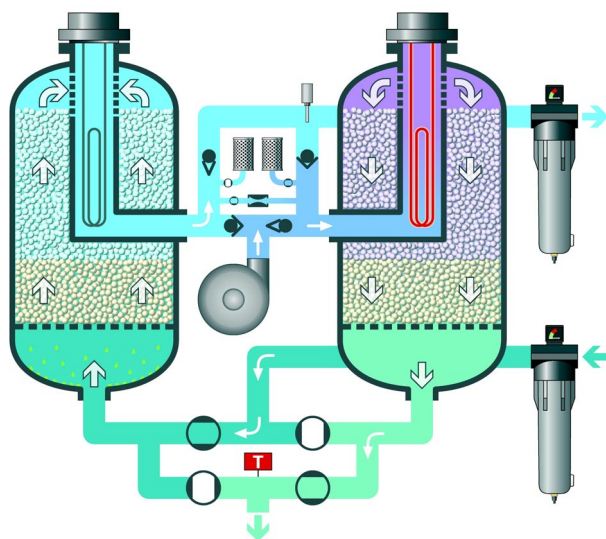

Fig. 5: Heated regeneration

Control

All heatless or heated-regenerated adsorption dryers are equipped with a time-dependent control. This comes as a manufacturer-specific variant or PLC depending on the extent of control required. A load-dependent control is an optional supplement. At the dryer outlet, a sensor registers changes of the pressure dew point. It automatically adjusts the cycle of the dryer to the load situation. The load-dependent control compensates possible part-load situations and reduces operating costs.

- + Minimum operating costs even at part-load operation
- + continuous pressure dew point measurement for quality control.

Membrane dryer

The membrane dryer is a supplement and alternative to the traditional refrigeration and adsorption dryers. It is particularly effective as a point-of-use dryer for smallest compressed air quantities, non-continuous operation or applications without electrical energy.

The heart of these membrane dryers are polymer hollow tube membranes which allow the water vapour to diffuse.

Filtration

This is used to remove contaminants from the compressed air to a large extent.

The main contaminants include oil vapour from oil-lubricated or oil-injected compressors as well as solid particles and hydrocarbons from the ambient air which are then contained in concentrated form in the compressed air. To guarantee the compressed air quality required today, purification is mandatory.

Due to an increased environmental awareness as well as stricter measures of health protection at work, requirements are also made of the emission values of the compressed air expanded after use, specifically with regard to oil vapour, which is emitted to the ambient air, e.g. directly from a compressed air cylinder or a nozzle.

However, filters also consume energy. Although there is no energy input to a filter, energy is consumed by the filter due to the pressure drop (differential pressure) caused which has to be provided by the compressor located upstream of the filter. The following rule applies:

The higher the degree of filtration, i. e. the greater the purity of the filtered air, the higher the differential pressure, i. e. the greater the amount of energy which has to be supplied by the upstream compressor.

Filters are therefore necessary, but cost energy and thus money. It is important to select the right quality of purification depending on the application involved. ISO 8573-1 or the manufacturer concerned can help with the selection.

It makes sense to think carefully about the degree of compressed air purity actually required, in order to individually select the filter(s) with the lowest possible differential pressure for the applications involved. Fig. 6 shows the saving potentials concerned. It shows the energy costs caused by compressors in compensating the pressure drop caused by the filter. These costs can amount to several thousand euro per year and may far exceed the purchase or replacement costs of the element. Enormous savings can be achieved by selecting the correct filter with the lowest possible differential pressures.

Timing the replacement of dirty filters correctly, which have increased differential pressure, is equally important. As shown in Fig. 7, the differential pressure of a new filter element increases very slowly at first. The longer the element is in operation, the quicker the differential pressure increases. If this element is not replaced, the costs of covering the additional differential pressure are sometimes many times higher than the price of a replacement. As a rule:

Replace elements once a year, at the latest at a differential pressure of 350 mbar

Activated charcoal filters are the exception to this rule. Here, the following rule applies:

Service life of the elements: max. 1,500 operating hours or 3 months, depending on the inlet temperature and the oil content sometimes much shorter.

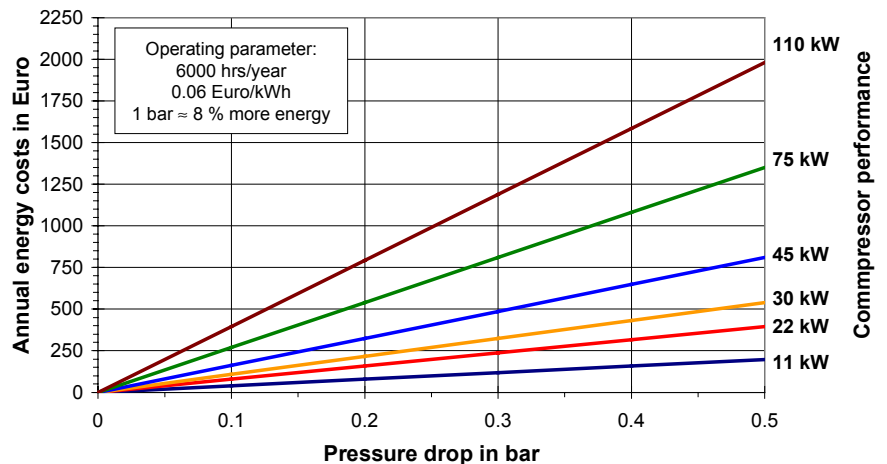

Fig. 6: Energy costs due to pressure drops

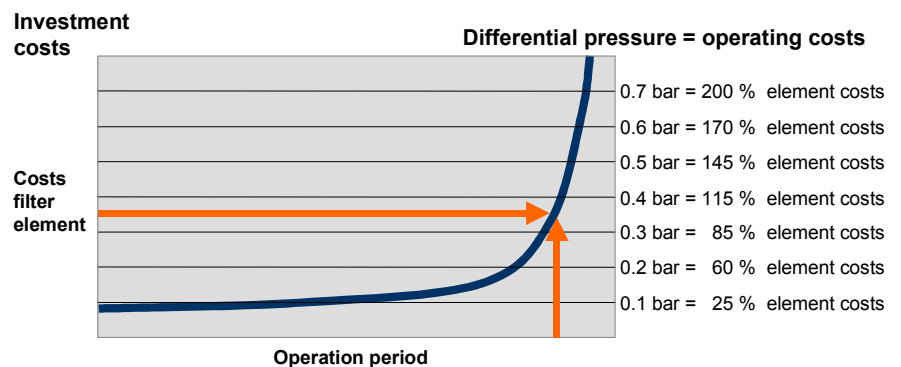

Fig. 7: Typical differential pressure; ratio of energy costs to filter element costs

Finally there is the question of the operating safety of a filter. This criterion depends primarily on the quality of the tools used, the quality of production and the design features of the filter. The filter construction has to be assessed individually. The criteria for a filter are summarised below:

Filtration efficiency
+Operating safety
+Differential pressure
=Total operating costs

The sum of these three criteria then determines the total operating costs of the filter, breakdown costs due to insufficient filtration or a failure of the filter are already included.

Preliminary separation

The first treatment stage in a compressed air system is the separation of free condensate from the compressed air. To do so, a cyclone separator or a receiver is used at the compressor outlet. The **receiver** is the simplest system. By reducing the flow velocity and cooling the compressed air on the large surface area of the receiver, the condensate is collected at the bottom of the receiver and can be drained. With its vortex, the **cyclone separator** utilises mass inertia for separation. Both systems improve the performance of the compressed air treatment since considerable amounts of condensate are removed. Neither component replaces compressed air drying since the compressed air is saturated with 100 % water vapour after these separators and free water condenses with each further cooling of the air.

Condensate technology

Condensate is an inevitable by-product of producing compressed air. This condensate is formed from the humidity contained in the input air. At compression and the associated increase in temperature, this humidity is first present as vapour. Because only a minor fraction of the original volume remains after compression, the air becomes oversaturated. When cooled, the air humidity is precipitated as condense water. Apart from water and oil, this condensate also contains all the other components of the ambient air

sucked in by the compressor. These are concentrated and result in contamination of the condensate.

Consequences of the condensate for the compressed air system:

Condensate, irrespective of whether it contains oil or not, results in corrosion in the pipe system and downstream processes. Whereas oil-free condensate has a more acidic effect due to its pH value, oily condensates have the effect of clogging and sticking. The air quality required, even at lower classes, can no longer be achieved.

Where is the condensate formed?

Condensate is always formed if the temperature in the compressed air falls below the pressure dew point. This happens in after-coolers, receivers, cyclone separators, filters, dryers and in the pipe system. The largest amount of condensate is precipitated at the point of the greatest temperature drop after compression.

Trapping condensate

Due to the high costs of the resulting damage, removing the condensate from compressed air is assigned a very high priority. There are three common ways to trap condensate:

Float control:

The condensate is collected in a storage tank. A float opens a valve when a certain condensate volume is reached.

- + low investment
- very sensitive to dirt
- no monitoring possibilities.

Time-controlled valves:

A valve operated by a timer switch opens at a fixed interval.

- + large opening diameter
- + also available in a high pressure version
- compressed air loss
- high energy cost
- no monitoring and operational checks.

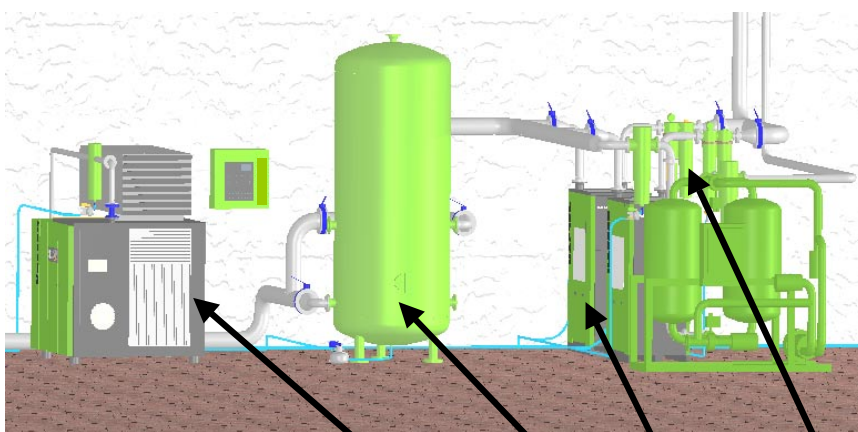

Condensate yield per 10 standard cubic metre in	Cyclone separator Aftercooler	Receiver	Refrigeration dryer	Filter
Winter	25 g/m ³	3.5 g/m ³	3.5 g/m ³	--
Spring/Autumn	28 g/m ³	6 g/m ³	9.5 g/m ³	2 g/m ³
Summer	53 g/m ³	9.5 g/m ³	21.5 g/m ³	3 g/m ³

Fig. 8: Condensate yield according to season



Fig. 9: Time-controlled valve

Electronic level-controlled separator

A sensor located in the condensate collector triggers the draining of the tank when a set value is reached.

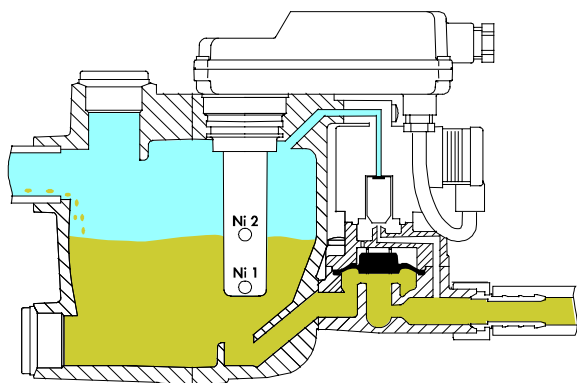

Fig. 10: Level-controlled separator

- + Energy saving
- + no compressed air losses
- + fault and alarm functions.

Condensate treatment

From the legal viewpoint, compressor condensate constitutes waste which requires particular monitoring. The law offers a choice of two possibilities for treating condensate. Either the specialist disposal by authorised companies or treatment on site with suitable and certified treatment technology. Condensates occur either as oil/water mixes or stable emulsions. In practice, these are the main methods.

Static oil/water separator

In this process, the condensate is held for a predefined retention time in a separating tank. The lighter oil components rise to the surface. The fine residue and other substances are filtered out in a downstream activated carbon stage. This method is always sufficient if the condensate is present in a disperse form.

- + simple system
- + fast amortisation.

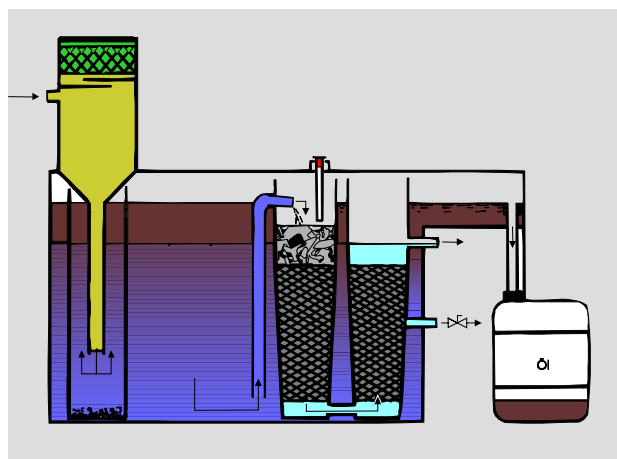

Fig. 11: Static oil/water separation system

Emulsion separation systems based on adsorption

With this method, a reaction separating agent is added to the pre-cleaned condensate. Electrolytes contained in the separating agent break down the oil-water compound and thus split the emulsion. The oil and other components of the condensate are adsorbed by the aluminium oxide and filtered out of the water. Only the residue formed has to be taken for disposal.

Ultrafiltration

With ultrafiltration, the condensate is circulated under pressure and filtered through a membrane with a controlled pore width. The oil components are retained and concentrated, while the water is purified and then discharged into the waste water system without any further filtering. The concentrated emulsion is then disposed of.

In each case, care must be taken when buying appliances and replacement parts that these are licensed, otherwise expensive individual technical approval of the appliances has to be conducted by the local authorities.

Summary

Compressed air treatment in air mains is state of the art today. The basic demand made of this treatment technology is the reliable and high-level removal of the contamination and humidity from the compressed air. This contamination leads to quality reductions and disturbances up to unusable products. How complex this treatment has to be and which operating costs are incurred can be clearly influenced by comparing the products found on the market and selecting the most suitable for a particular application.

In the compressed air treatment sector, the main concern is to achieve the optimum quality by fulfilling the specification of the application at optimum energy and operating costs. Increased energy or operating costs result from exceeding or failing to meet this specification. Figs. 12 and 13 give an overview of which order and choice of treatment products achieve which compressed air quality.

The available savings potential per subcomponent can amount to several thousand euro. Specifically, regular replacement of filter elements within the prescribed intervals can achieve obvious savings and thus minimise operating costs.

The serious analysis of the installed or planned compressed air system represents an investment which sometimes pays off very quickly.

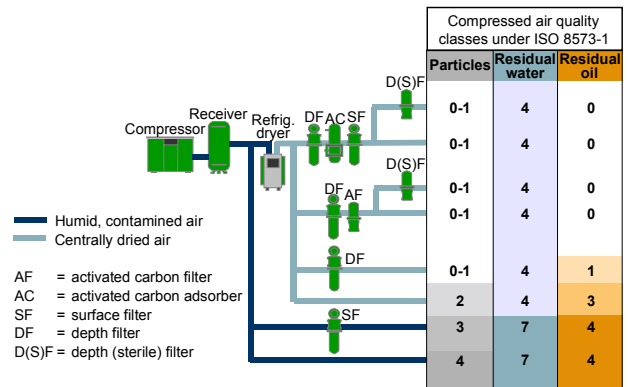

Fig. 12: Compressed air quality when using refrigeration dryers

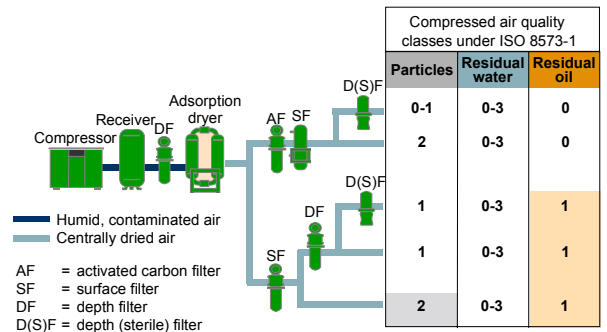

Fig. 13: Compressed air quality when using adsorption dryers



The campaign "Druckluft effizient" aims to motivate the operators of compressed-air systems to optimise their systems and save substantial costs. It is conducted by the **German Energy Agency** (dena), the **Fraunhofer Institute Systems and Innovation Research** (Fraunhofer ISI; project management), and the **Federation of the Engineering Industries** (VDMA) with support of the Federal Ministry for Economics and Labour (BMWA) and the following industrial enterprises:

- | | | |
|---------------------|---------------------------|------------------------------|
| Atlas-Copco | BEKO Technologies | BOGE Kompressoren |
| domnick-hunter | Energieagentur NRW | Gardner Denver Wittig |
| GASEX | Gebr. Becker | Ingersoll-Rand |
| Kaeser Kompressoren | Legris – TRANSAIR | METAPIPE |
| Schneider Druckluft | systemplan, Karlsruhe | Thyssen Schulte – MULTIPLAST |
| ultra air | ultrafilter International | ZANDER Aufbereitungstechnik |

Further information can be found at www.druckluft-effizient.de